

# SCT Series

HOUSINGS  
SINGLE CARTRIDGE  
HIGH PRESSURE



## MAIN APPLICATION:

- DESALINATION
- WATER TREATMENT
- FINE CHEMICAL
- PETROCHEMICAL
- OIL & GAS
- FOOD & BEVERAGE
- POWER GENERATION
- PAINTS AND RESIN
- GALVANIC
- HYDRAULIC
- STEEL MILL
- GENERAL INDUSTRY

## CHARACTERISTICS:

- 100% AISI 316 construction
- Head and body flange manufactured with lost wax micro-casting
- Conform to 2014/68/UE PED Directive
- Conform to 2014/34/UE ATEX Directive
- 1935/2004/CE certification available upon request
- Stud bolts and nuts head/bowl closure
- Suitable for liquid or gas Gr. 1 and 2 filtration
- In line in/out connections for easy installation
- Suitable for pressure up to 69 bar
- Model for steam application at 25 bar / 200 °C available
- Suitable for cartridges from 6" to 40"
- Suitable for cartridges DOE or M3; M6 and M7 as option
- Installation of cartridge independent from bowl
- O-ring head/bowl seal
- Designed to allow visual checking of the installed cartridge prior to bowl closure
- ASME design available as option

# ASCO FILTRI

a **mott** company

# SCT Series

**HOUSINGS**  
**SINGLE CARTRIDGE**  
**HIGH PRESSURE**

## TECHNICAL DATA

### MAX. WORKING CONDITION

- 25 bar @ 100 °C (LP series)
- 69 bar @ 100 °C (HP series)
- 25 bar @ 200 °C (ST series)
- (according to the handled fluid)

### CONSTRUCTION MATERIAL

- HEAD:**
- 316 SS micro casting
- BODY FLANGE:**
- 316 SS micro casting
- BOWL:**
- 316L SS

### FILTER FINISHING

- Internal:**
- Pickling
- External:**
- Glass bead blasted

### GASKETS

- EPDM
- Buna-n
- Silicone
- Viton
- PTFE
- FEP

### IN/OUT

- 1" NPT-F

### DRAIN

- 3/8" NPT-F

### ACCESSORIES

- Flanged connections

## Dimensions:

Length	Dimension [mm]			Connections		Volume [lt]	Weight [kg]
	A [1]	B DOE	B cod.7	In/out	Drain		
06	110	270	293	1" NPT-F	3/8" NPT-F	1.2	7.5
10	110	375	375			1.6	9.0
20	110	626	641			3.0	13.0
30	110	881	896			4.5	15.0
40	110	1120	1131			5.7	22.0

1] For flanged version contact Asco Filtri.

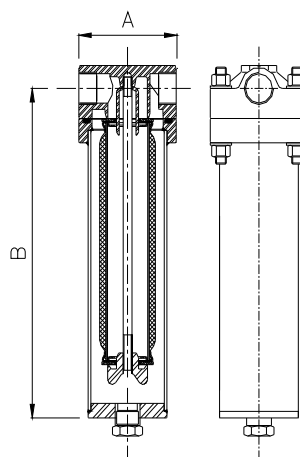

## Max. working pressure:

Fluid	SCT-LP				SCT-HP			
	10"	20"	30"	40"	10"	20"	30"	40"
Liquid Gr. 2	25 bar	25 bar	25 bar	25 bar	69 bar	69 bar	69 bar	69 bar
Liquid Gr. 1	25 bar	25 bar	25 bar	25 bar	69 bar	65 bar	43 bar	34 bar
Gas Gr. 2	25 bar	25 bar	25 bar	25 bar	69 bar	65 bar	43 bar	34 bar
Gas Gr. 1	25 bar	15 bar	10 bar	8 bar	30 bar	15 bar	10 bar	8 bar

Where the 2014/68/UE PED Directive is applicable, in case dangerous of gas Gr. 1, the max. working pressure must be reduced.  
 For different working pressure check with the operating manual.

## Gaskets temperature limitation:

EPDM	120 °C	Viton	230 °C	PTFE	250 °C
Buna-n	120 °C	Silicone	230 °C	FEP	250 °C

Working temperature is limited from installed gaskets.  
 For different working temperature check with the operating manual.

**Contact us for any further information.**

We reserve the right to change the data of this specification without notice.

**ASCO Filtri S.p.A.**

Viale delle Scienze, 8  
 20082 Binasco (MI) - Italy

Phone: +39 02 89703.1

Fax: +39 02 89703.410

E-mail: info@ascofiltri.com

Web: www.ascofiltri.com

**ASCO**  
**FILTRI**